

EXTERIOR LOUVERS SLK48



Introduction



Technical specifications



Featuring options

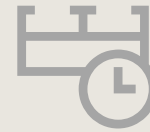

Variations



Summary

INTRODUCTION

Introducing our innovative exterior sliding louvers SL48 system. A dynamic solution designed to enhance both the aesthetics and functionality of any building facade. This cutting-edge system consists of adjustable louvers that seamlessly slide along the exterior side of the wall, offering unparalleled control over light, ventilation, and privacy. With its sleek design and customizable features, our exterior sliding louver system is poised to revolutionize architectural possibilities.

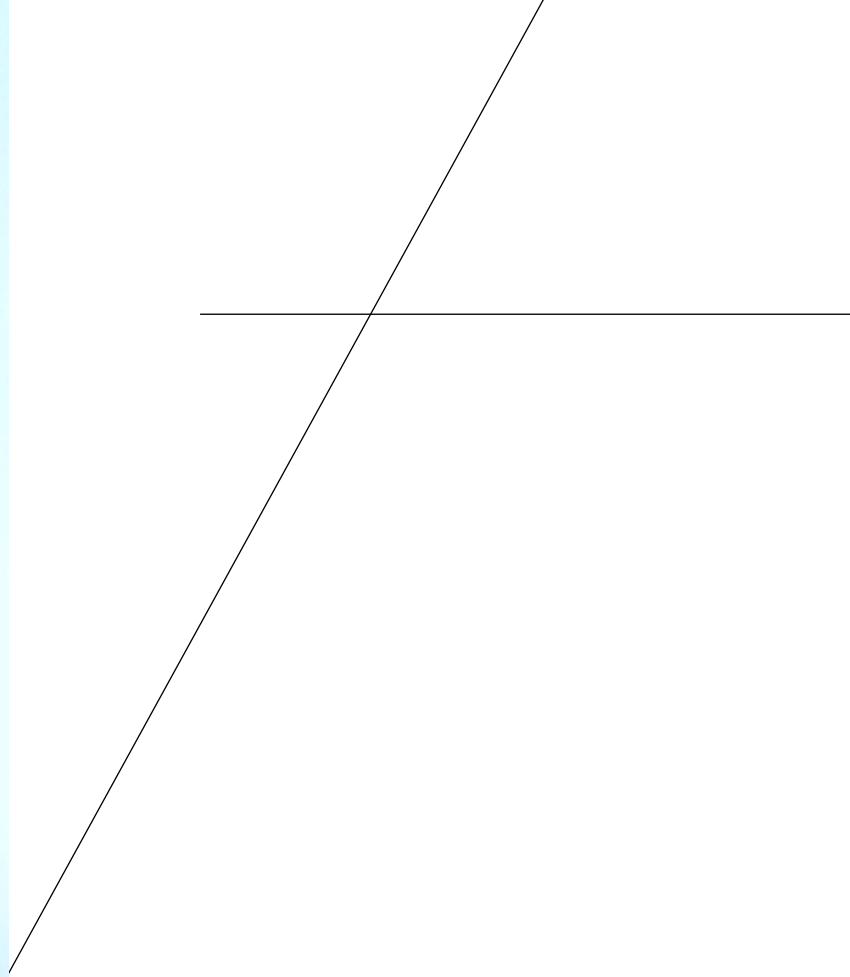

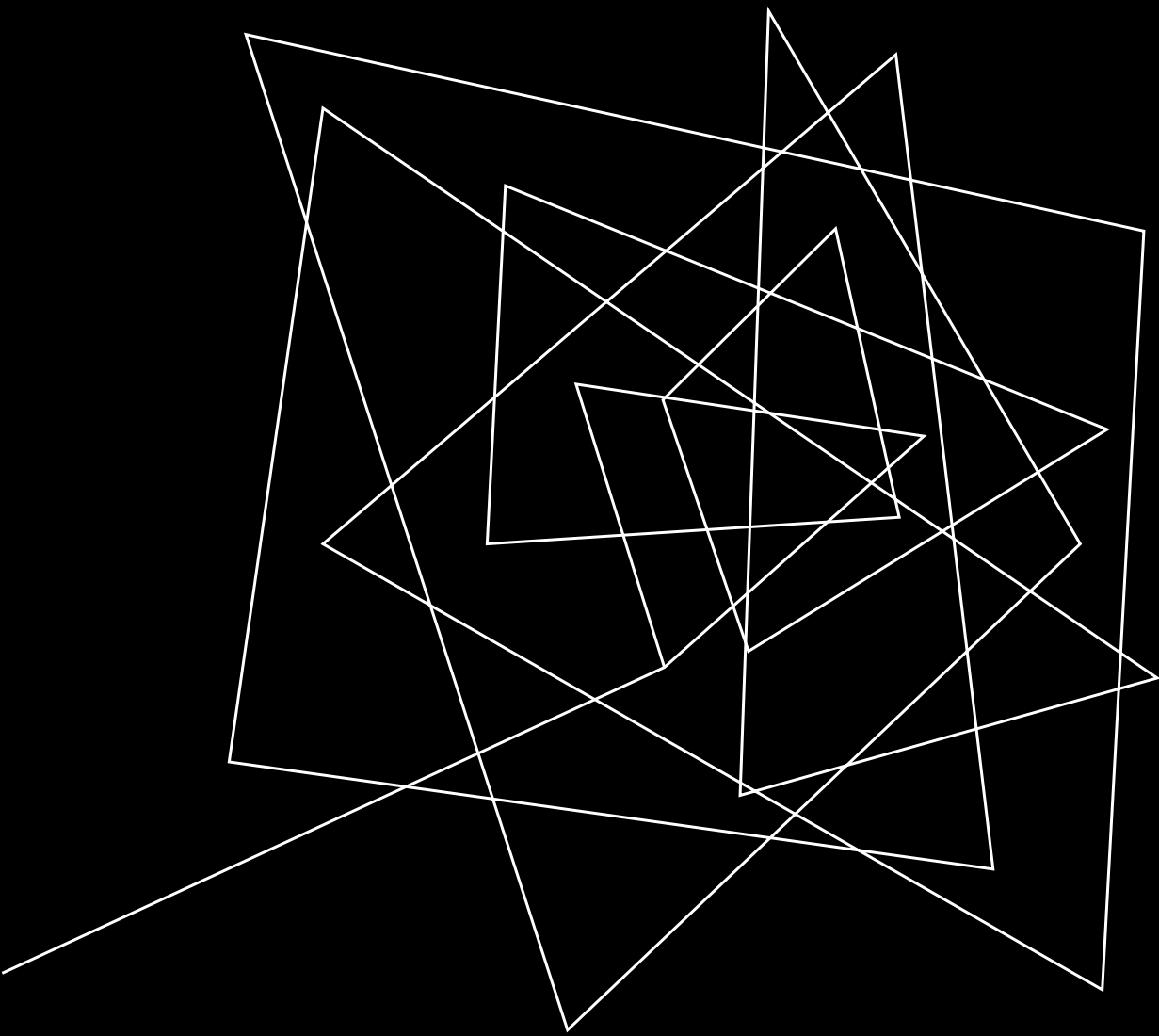

TECHNICAL SPECIFICATIONS

SYSTEM SLK48

Dimensions:

- Maximum Aperture Width: 2800mm
- Aperture Height: Up to 2400mm
- Weight Capacity: 160kg (shared between one or two sashes)

Material:

- Louvers: UPVC with metal support for structural integrity
- Parts: Stainless steel, synthetic, and aluminum covers

Finishes:

- Louvers: Variety of laminated foils with different textures
- Aluminum Covers: Powder coating available

Louver Orientation:

- Sliding Direction: Horizontal
- Options: Single sash sliding left, single sash sliding right, or double sash sliding to the sides (left and right)

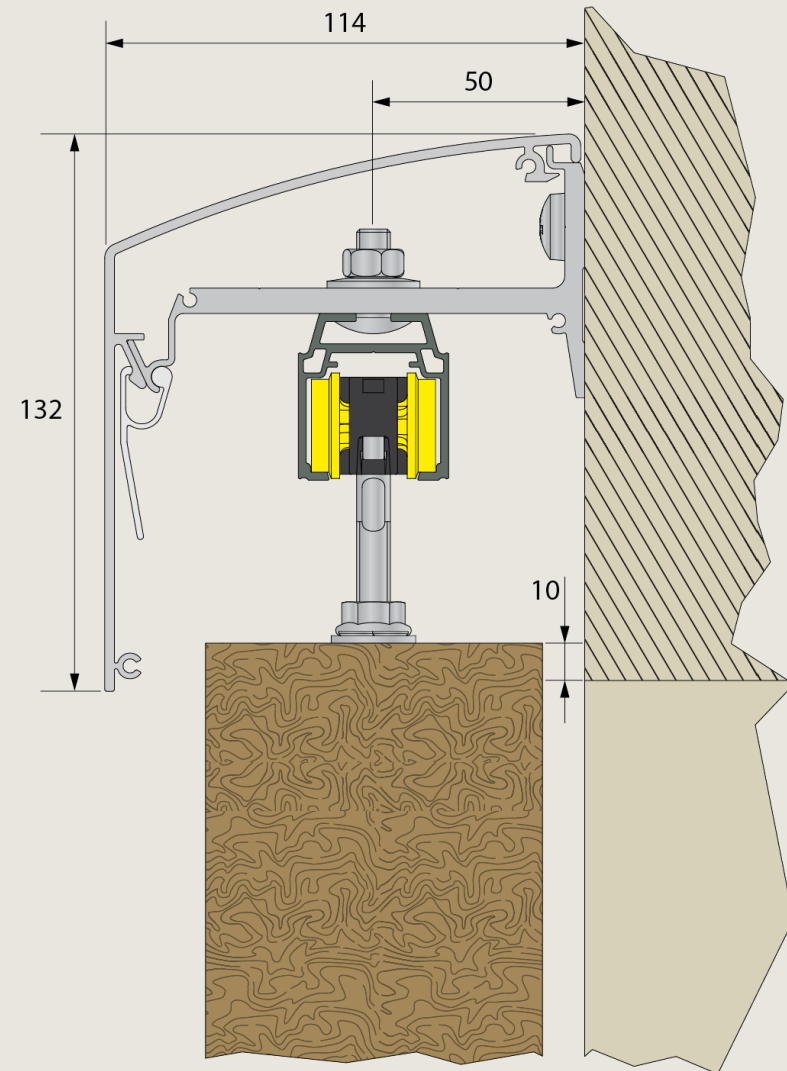

FEATURING OPTIONS

Control Mechanism:

- Manual Operation: Locking hardware for manual control
- Motorized Operation: Obstacle detection system, remote controlled

Blade Angle Adjustment:

- Louvers fixed by default
- Rotary mechanism available for adjustable blade angle and increased airflow

Weather Resistance:

- Highly resistant to seaside environment
- Corrosion-resistant materials
- Minimal maintenance requirements

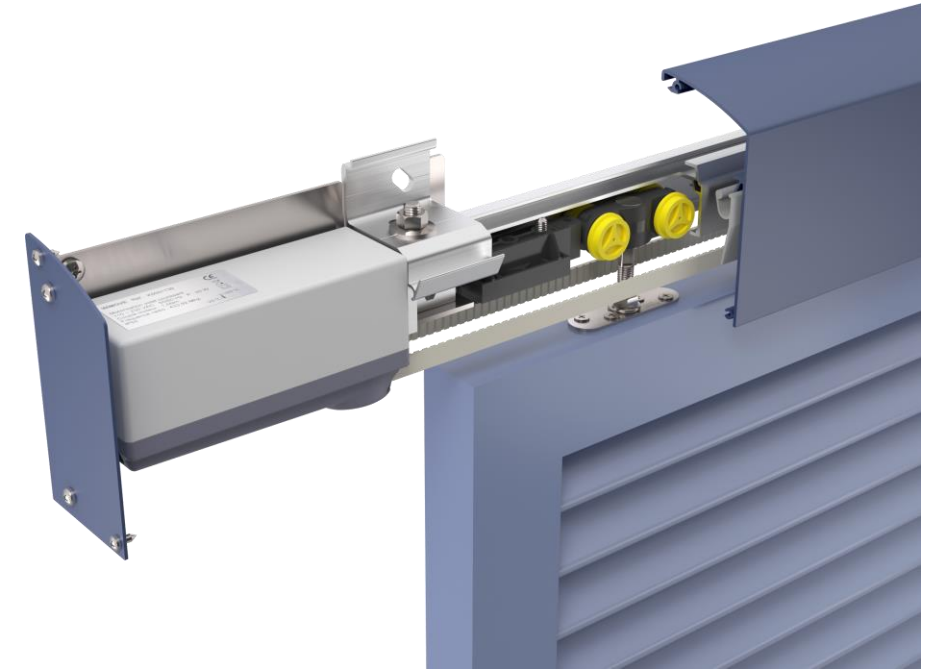
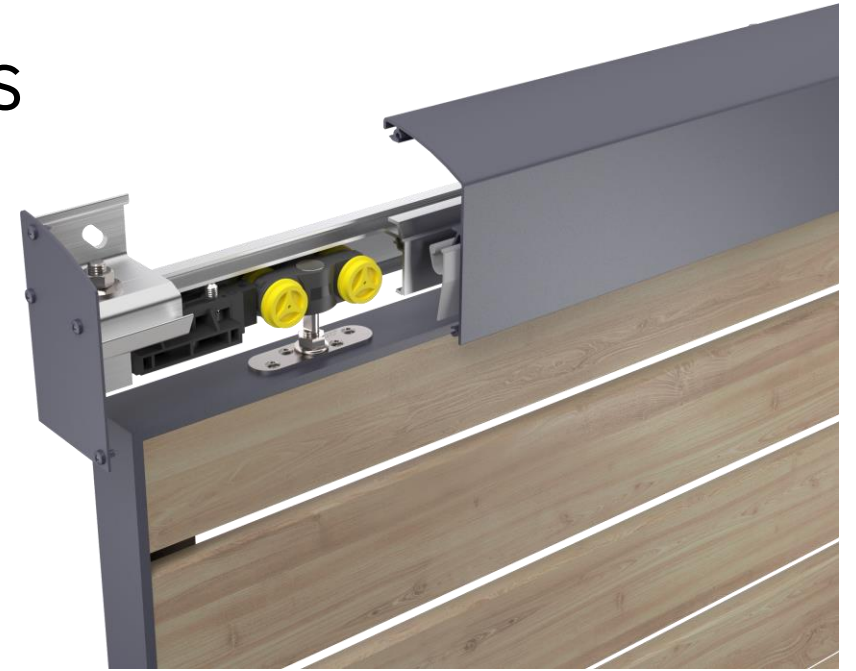

Security and Privacy:

- Manual Version: Locking hardware for enhanced security
- Motorized Version: Battery pack for power backup during electricity failures

Integration:

- Motorized version can be integrated with a central unit or automation systems

Quantity:

- Customized to size and type of filling

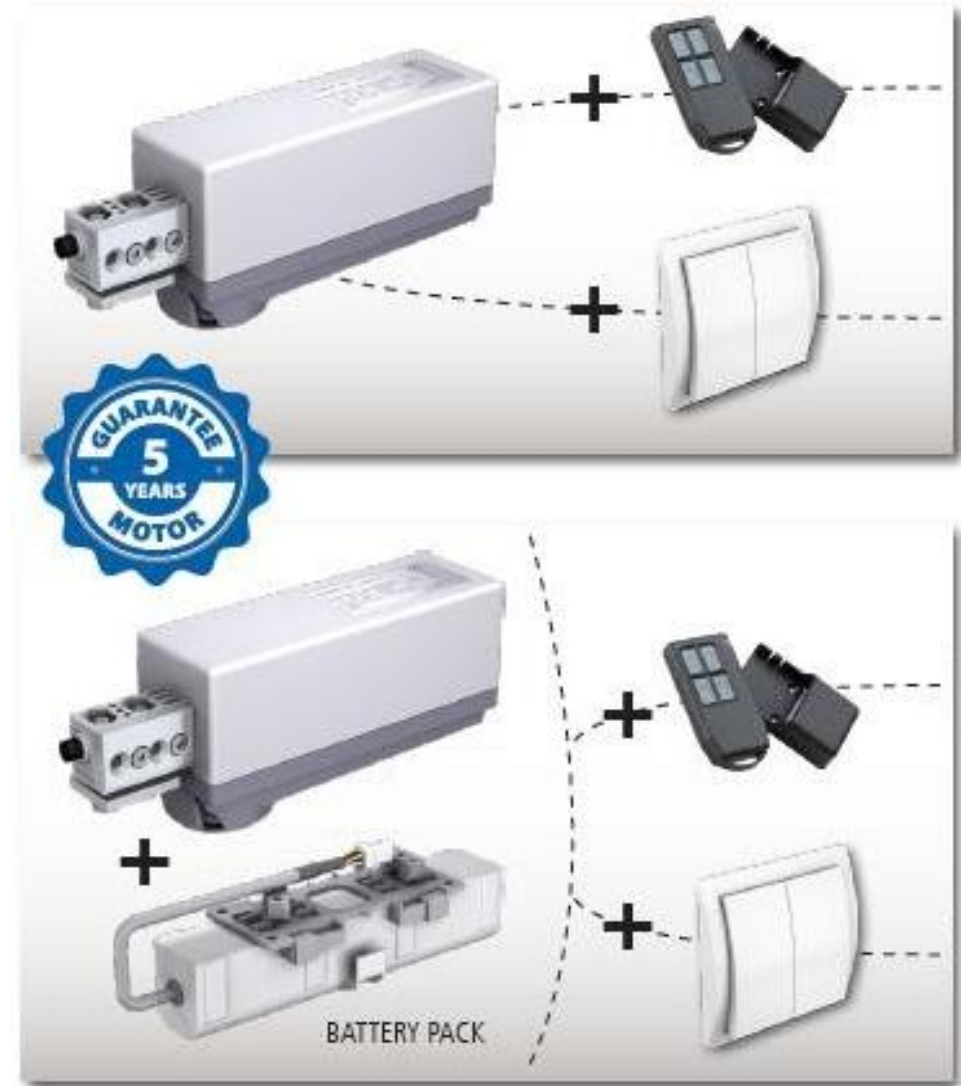
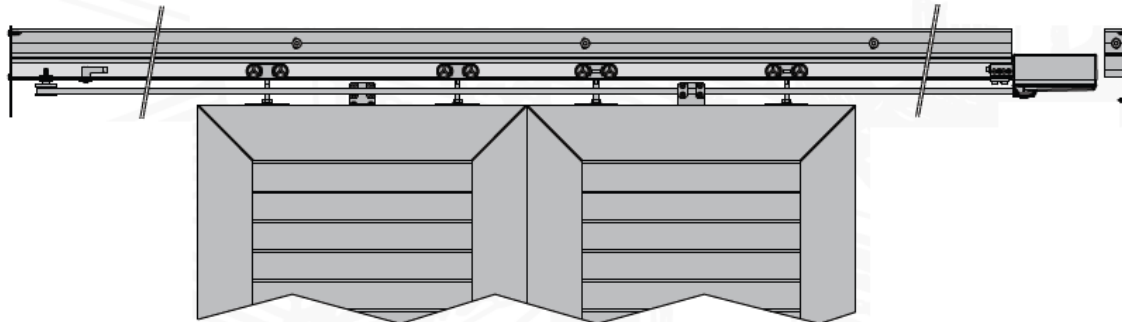

SYSTEM SASH VARIATIONS

Configurations possibles

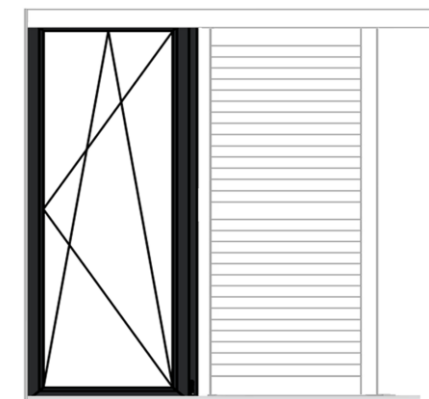
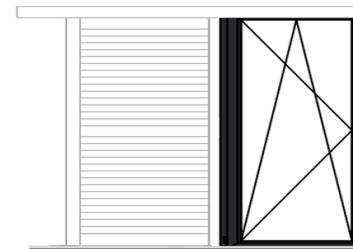
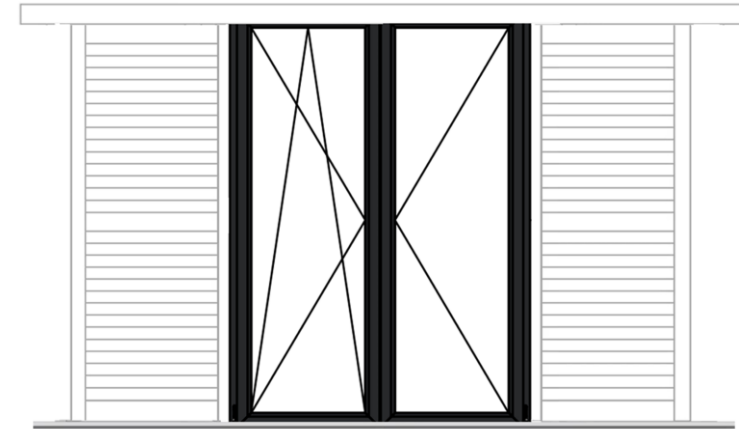



SUMMARY & APPLICATIONS

SLK48 is an innovative exterior sliding louver system proudly brought to you by Kaptain. With its cutting-edge design and exceptional functionality, SLK48 revolutionizes building facades by providing unparalleled control over light, ventilation, and privacy. Crafted with high-quality UPVC with metal support and stainless-steel components, SLK48 ensures durability and structural integrity. Its customizable finishes, such as a variety of laminated foils and powder-coated aluminum covers, cater to diverse aesthetic preferences. Whether it's the manual operation with locking hardware or the motorized version equipped with obstacle detection and remote control, SLK48 offers flexibility and convenience. Experience superior craftsmanship and transform your building facade with SLK48 by Kaptain.









KAPTAIN S.A.
No1 GREEK uPVC WINDOWS INDUSTRY

The logo for KAPTAIN S.A. features the company name in a bold, white, sans-serif font. The letters 'A' and 'I' in 'KAPTAIN' have a distinctive shape. Above the text, there are two white, curved swooshes that extend horizontally across the top of the logo area.

www.kaptain.gr

T +302221032400

Vathi Avlidas Evia

Greece PC 34100